

Stella MD034 800x450

Height: 800
Width: 450
Depth: 75
Weight HO: 5.5 kg
EO: 9.5 kg

Tube ϕ : 30 + 22
Pipe Centres: 400
Elec. element if specified: 125
Output @ 50°C Δ T Watts: 412
BTUs: 1406

All dimensions in millimetres

Manufactured from 1.4301/X5CrNi18-10 stainless steel

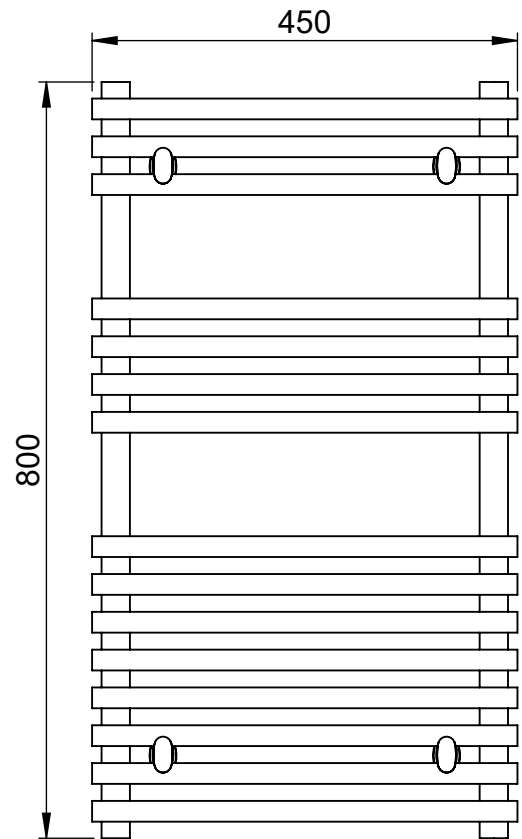
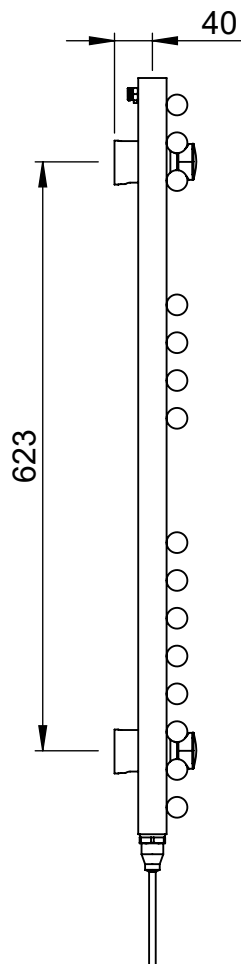
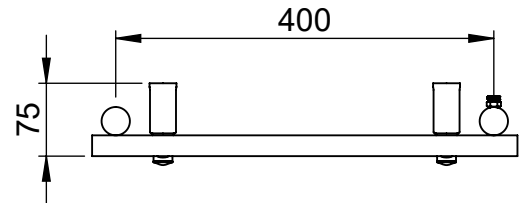
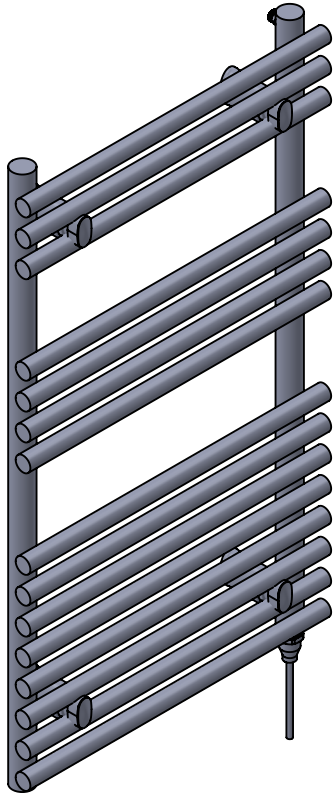

position of element
if specified dual
energy*/ electric

*Dual energy models require a conversion-tee, consult relevant drawing for details.

Vogue UK Ltd. reserve the right to alter specifications without prior notice.
ALL MEASUREMENTS ARE NOMINAL DIMENSIONS ONLY, AND ARE NOT BINDING.

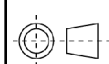

SCALE 1:8



VOGUE UK
TOWEL WARMERS & RADIATORS

Strawberry Lane, Willenhall
West Midlands WV13 3RS
Tel: 01902 387000 Fax: 01902 387001
e-mail: sales@vogueuk.co.uk www.vogueuk.co.uk